

915nm 10W Fiber Coupled Diode Laser

K915F02RN-10.00W (Standard Product)

Specifications(25°C)		Symbol	Unit	K915F02RN-10.00W		
				Minimum	Typical	Maximum
Optical Data ⁽¹⁾	CW-Output Power	P_o	W	10	-	-
	Center Wavelength	λ_c	nm	915±10nm		
	Spectral Width (FWHM)	$\Delta\lambda$	nm	6		
	Wavelength Shift with Temperature	$\Delta\lambda/\Delta T$	nm/°C	-	0.3	-
	Wavelength Shift with Current	$\Delta\lambda/\Delta I$	nm/A	-	1	-
Electrical Data	Electrical-to-Optical Efficiency	PE	%	-	48	-
	Operating Current	I_{op}	A	-	12	13
	Threshold Current	I_{th}	A	-	0.9	-
	Operating Voltage	V_{op}	V	-	1.6	2
	Slope Efficiency	η	W/A	-	0.9	-
Fiber Data ⁽²⁾	Core diameter	D_{core}	μm	-	105	-
	Cladding diameter	D_{clad}	um	-	125	-
	Buffer diameter	D_{buf}	um	-	250	-
	Numerical Aperture	N.A.	-	-	0.22	-
	Total Fiber Length	L_f	m	0.9	1	-
	Fiber Loose Tubing Diameter/Length	-	μm	0.9mm PVC 1.5cm		
	Minimum Bending Radius	-	mm	60	-	-
	Fiber termination	-	-	-	无	-
Feedback Isolation ⁽³⁾	Wavelength Range	λ	nm	1040~1200		
	Isolation	-	dB	-	30	-
Others	ESD	V_{esd}	V	-	-	500
	Storage Temperature (Non-operating) ⁽⁴⁾	T_{st}	°C	-20	-	70
	Lead Soldering Temp	T_{is}	°C	-	-	260
	Lead Soldering Time	t	sec	-	-	10
	Operating Case Temperature ⁽⁵⁾	T_{op}	°C	15	-	35
	Relative Humidity	RH	%	15	-	75

(1) Data measured under operation output at 10W.

(2) Other fiber type customized according to customers requirements.

(3) Other feedback isolation customized according to customers requirements.

(4) A non-condensing environment is required for operation and storage conditions are from -20 to +70 °C with relative humidity between 15 to 75 %.

(5) Operating temperature defined by the package case. Acceptable operating range is 15 - 35C, but performance may vary.

915nm 10W Fiber Coupled Diode Laser

K915F02RN-10.00W (Standard Product)

Characteristics

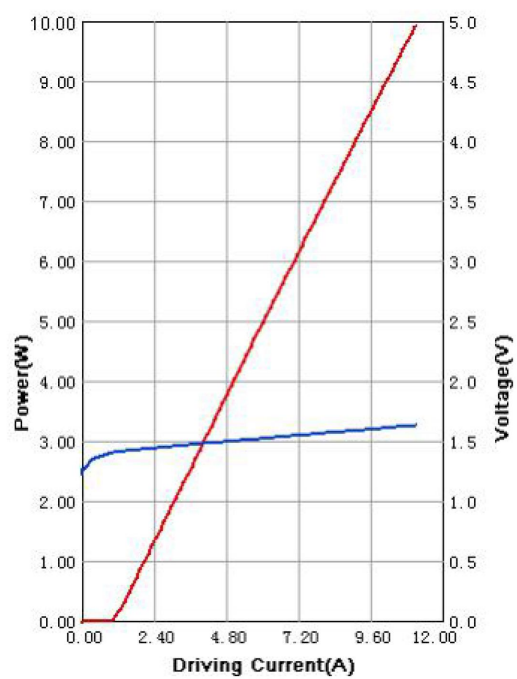

915nm 10W Fiber Coupled Diode Laser
K915F02RN-10.00W (Standard Product)

Package Dimensions (mm)

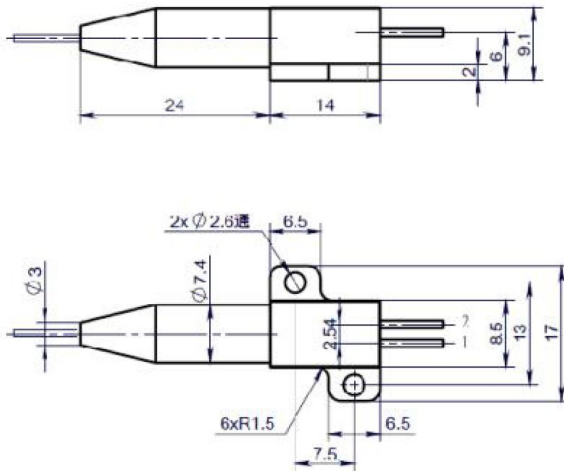

Pins	Function
1	LD (+)
2	LD (-)

OPERATING NOTES

- ◆ Avoid eye exposure to direct or scattered radiation.
- ◆ ESD precautions must be taken.
- ◆ Please connect pins to wires by solder instead of using socket when operation current is higher than 6A.
- ◆ Soldering point should be close to the root of the pins. Soldering temperature should be lower than 260°C and time shorter than 10 second.
- ◆ Use constant current power supply. Avoid surge current.
- ◆ Laser diode must be used according to the specifications.
- ◆ Laser diode must work with good cooling.
- ◆ A minimum bend radius should be 300 times greater than the fiber cladding diameter, dynamic bend radius should be 400 times greater than the fiber cladding diameter.
- ◆ Operation temperature is 15°C~ 35°C.
- ◆ Storage: -20°C~ +70°C, all pins short-circuit.



Declaration: information and specifications contained herein are deemed to be reliable and accurate. BWT Beijing reserves the right to change, alter or modify the design and specifications of these products at any time without notice.18-1